



**CITY OF SPRINGFIELD, MISSOURI
DIVISION OF PURCHASES
INVITATION FOR BID #115-2010**

THIS IS NOT AN ORDER

RETURN

TO: Scott Menzer, Buyer
City of Springfield
Division of Purchases
218 E. Central
Springfield, MO 65802

Date Issued: April 8, 2010
Buyer's Email: smenzer@springfieldmo.gov
Telephone Number: 417-864-2079
Fax Number: 417-864-1927
Pre-Bid: April 14, 2010 at 9:00 am
DUE DATE: April 20, 2010

BIDS MUST BE PHYSICALLY RECEIVED IN THE DIVISION OF PURCHASES PRIOR TO 3:00 P.M. ON TUESDAY, APRIL 20, 2010. Bids will be opened by the buyer at the location listed above.

- Bids shall be submitted on the forms provided and must be manually signed by the individual authorized to legally bind the company.
- Bids shall be submitted with the IFB number clearly indicated on the outside of the mailing envelope.
- Bids received after the opening date and time will be rejected.
- The attached Terms and Conditions shall become part of any purchase order resulting from this bid.
- **FAXED/EMAILED BIDS WILL NOT BE ACCEPTED.**

You are invited to submit your bid to furnish the materials and/or services described herein. Please submit your prices/fees net of all discounts.

DESCRIPTION

TURN-KEY OVERHEAD DOOR REPLACEMENT

See attached General Conditions, Specifications, and Bid Form for detailed information.

DELIVERY: F.O.B. DESTINATION

The articles to be furnished hereunder shall be delivered all transportation charges paid by the bidder to destination.

It is the intent of the City that this Invitation for Bid promotes competitive bidding. It shall be the Vendor's responsibility to advise the Division of Purchases if any language, requirements, etc. any combination thereof, inadvertently restricts or limits the requirements stated in this Invitation for Bid to a single source. Such notification must be submitted in writing and must be received by the Division of Purchases not later than three (3) days prior to the bid opening date.

**CITY OF SPRINGFIELD
INSTRUCTION TO BIDDERS**

01. Opening Location

The Bids will be opened at the City of Springfield, Division of Purchases, 218 E. Central, Springfield, MO 65802 in the presence of Purchasing officials at the due date and time indicated on the IFB. All bidders or their representatives are invited to attend the opening of the IFB.

02. IFB Delivery Requirements

Any Bids received after the above stated time and date will not be considered. It shall be the sole responsibility of the bidder to have their Bid delivered to the Division of Purchases for receipt on or before the due date and time indicated. If a Bid is sent by U.S. Mail, the bidder shall be responsible for its timely delivery to the Division of Purchases office. Bids delayed by mail shall not be considered, shall not be opened, and shall be rejected. Arrangements may be made for their return at the bidder's request and expense. Bids may be mailed to the Division of Purchases and accepted if the signed bid form and required information was mailed and received prior to the due date and time. Bids sent by email will not be accepted.

03. Sealed and Marked

If sent by mail, one original signed Bid shall be submitted in one sealed package, clearly marked on the outside of the package with the Invitation for Bid number and addressed to:

City of Springfield
Division of Purchases
218 E. Central
Springfield, MO 65802

04. Legal Name and Signature

Bids shall clearly indicate the legal name, address, and telephone number of the bidder (company, firm, corporation, partnership, or individual). Bids shall be manually signed above the printed name and title of signer on the Affidavit of Compliance page. The signer shall have the authority to bind the company to the submitted Bid. Failure to properly sign the Bid form shall invalidate same, and it shall not be considered for award.

05. Corrections

No erasures are permitted. If a correction is necessary, draw a single line through the entered figure and enter the corrected figure above it. Corrections must be initialed by the person signing the Bid.

06. Clarification and Addenda

Each bidder shall examine all Invitation for Bid documents and shall judge all matters relating to the adequacy and accuracy of such documents. Any inquiries or suggestions, concerning interpretation, clarification, or additional information pertaining to the Invitation for Bid shall be made through the Division of Purchases in writing or through email. The Division of Purchases shall not be responsible for oral interpretations given by any City employee, representative, or others. The issuance of written addenda is the official method whereby interpretation, clarification, or additional information can be given.

It shall be the responsibility of each bidder, prior to submitting their Bid, to contact the Division of Purchases at phone number 417-864-1620, or to check the Purchasing website to determine if addenda were issued and to make such addenda a part of their Bid at: www.springfieldmo.gov/egov/finance/bid_center.html

07. IFB Expenses

All expenses for making Bids to the City are to be borne by the bidder.

08. Irrevocable Offer

Any Bid may be withdrawn up until the due date and time set for opening of the IFB. Any Bid not so withdrawn shall, upon opening, constitute an irrevocable offer for a minimum period of 90 days to sell to the City the goods or services set forth in the IFB, until one or more of the Bids have been duly accepted by the City.

09. Responsive and Responsible Bidder

To be responsive, a bidder shall submit a Bid which conforms in all material respects to the requirements set forth in the Invitation for Bid. To be a responsible bidder, the bidder shall have the capability in all respects to perform fully the contract requirements, and the tenacity, perseverance, experience, integrity, reliability, capacity, facilities, equipment and credit which will ensure good faith performance. The lowest responsible bidder shall mean the bidder who makes the lowest Bid to sell goods or services of a quality which conforms closest to the quality of goods or services set forth in the specifications or otherwise required by the City and who is known to be fit and capable to perform the Bid as made.

10. Reserved Rights

The City reserves the right to make such investigations as it deems necessary to make the determination of the bidder's responsiveness and responsibility. Such information may include, but shall not be limited to: current financial statement, verification of availability of equipment and personnel, and past performance records.

11. The Right to Audit

The bidder agrees to furnish supporting detail as may be required by the City to support charges or invoices, to make available for audit purposes all records covering charges pertinent to the purchase, and to make appropriate adjustments in the event discrepancies are found. The cost of any audit will be paid by the City. The City shall have the right to audit the bidder's records pertaining to the work/product for a period of three (3) years after final payment.

12. Applicable Law

All applicable laws and regulations of the State of Missouri and the City including the City Procurement Regulations and Procedures will apply to any resulting agreement, contract, or purchase order. Any involvement with the City Procurement shall be in accordance with the Procurement Regulations and Procedures.

13. Right to Protest

Appeals and remedies are provided for in the City Procurement Regulations. Protestors shall seek resolution of their complaints initially with the City Purchasing Agent.

Any protest shall state the basis upon which the solicitation or award is contested and shall be submitted within ten (10) calendar days after such aggrieved person knew or could have reasonably been expected to know of the facts giving rise thereto.

14. Ethical Standards

With respect to this IFB, if any bidder violates or is a party to a violation of the general ethical standards of the City Procurement Code or the State of Missouri Statutes, such bidder may be disqualified from furnishing the goods or services for which the Bid is submitted and shall be further disqualified from submitting any future Bids. A copy of the City's General Ethical Standards is available at the Division of Purchases.

15. Collusion

By offering a submission to this Invitation for Bid, the bidder certifies the bidder has not divulged, discussed, or compared the Bid with other bidders and has not colluded with any other bidder or parties to this IFB whatsoever. Also, the bidder certifies, and in the case of a joint Bid, each party thereto certifies as to their own organization, that in connection with this IFB:

- a. Any prices and/or cost data submitted have been arrived at independently, without consultation, communication, or agreement for the purpose of restricting competition, as to any matter relating to such prices and/or cost data, with any other bidder or with any competitor.
- b. Any prices and/or cost data for this Bid have not knowingly been disclosed by the bidder and will not knowingly be disclosed by the bidder prior to the scheduled opening directly or indirectly to any other bidder or to any competitor.
- c. No attempt has been made or will be made by the bidder to induce any other person or firm to submit or not to submit a Bid for the purpose of restricting competition.
- d. The only person or persons interested in this Bid, principal or principals are named therein and that no person other than therein mentioned has any interest in this Bid or in the contract to be entered into.
- e. No person or agency has been employed or retained to solicit or secure this contract upon an agreement or understanding for a commission, percentage, brokerage, or contingent fee exempting bona fide employees or established commercial agencies maintained by the Purchaser for the purpose of doing business.

16. Contract Forms

Any agreement, contract, or purchase order resulting from the acceptance of a Bid shall be on forms either supplied by or approved by the City.

17. Liability and Indemnity

- a. In no event shall the City be liable to the Contractor for special, indirect, or consequential damages, except those caused by the City's gross negligence or willful or wanton misconduct arising out of or in any way connected with a breach of this contract. The maximum liability of the City shall be limited to the amount of money to be paid or received by the City under this contract.
- b. The Contractor shall defend, indemnify and save harmless the City, its elected or appointed officials, agents and employees from and against any and all liability, suits, damages, costs (including attorney fees), losses, outlays and expenses from claims in any manner caused by, or allegedly caused by, or arising out of, or connected with, this contract, or the work or any subcontract thereunder (the Contractor hereby assuming full responsibility for relations with subcontractors), including, but not limited to, claims for personal injuries, death, property damage, or for damages from the award of this contract to Contractor.
- c. The Contractor shall indemnify and hold the City harmless from all wages or overtime compensation due any employees in rendering services pursuant to this agreement or any subcontract, including payment of reasonable attorneys' fees and costs in the defense of any claim made under the Fair Labor Standards Act, the Missouri Prevailing Wage Law or any other federal or state law.

18. IFB Forms, Variances, Alternates

Bids must be submitted on attached City IFB forms, although additional information may be attached. Bidders must indicate any variances from the City requested specifications and/or terms and conditions, on the IFB Affidavit of Compliance. Otherwise, bidders must fully comply with the City requested specifications and terms and conditions. Alternate Bids may or may not be considered at the sole discretion of the City Purchasing Agent.

19. Bid Form

All blank spaces must be completed with the appropriate response. The bidder must state the price, written in ink, for what is proposed to complete each item of the project. Bidders shall insert the words "no bid" in the space provided for an item for which no Bid is made. The bidder shall submit an executed Bid form, affidavit of compliance with other requested documents.

20. Modifications or Withdrawal of Bid

A modification for a Bid already received will be considered only if the modification is received prior to the time announced for opening of Bids. All modifications shall be made in writing, executed, and submitted on the same form and manner as the original Bid. Modifications submitted by telephone, fax, or email will not be considered.

21. No Bid

If not submitting a Bid, respond by returning the "Statement of No Bid" no later than the stated Bid opening time and date, and explain the reason in the space provided.

22. Errors in Bids

Bidders or their authorized representatives are expected to fully inform themselves as to the conditions, requirements, and specifications before submitting Bids; failure to do so will be at the bidder's own risk. Neither law nor regulations make allowance for errors either of omission or commission on the part of bidders. In case of error of extension of prices in the Bid, the unit price shall govern.

23. Prices Bid

Give both unit price and extended total. Price must be stated in units of quantity specified in the bidding specifications. In case of discrepancy in computing the amount of the Bid, the unit price of the Bid will govern. All prices shall be F.O.B. destination, freight prepaid (unless otherwise stated in special conditions). Each item must be bid separately and no attempt is to be made to tie any item or items in with any other item or items. If a bidder offers a discount on payment terms, the discount time will be computed from the date of satisfactory delivery at place of acceptance and receipt of correct invoice at the office specified. Payment terms shall be Net 30 if not otherwise specified. Pre-payment terms are not acceptable.

24. Discounts

Any and all discounts except cash discounts for prompt payments must be incorporated as a reduction in the Bid price and not shown separately. The price as shown on the Bid shall be the price used in determining award(s).

25. Descriptive Information

All equipment, materials, and articles incorporated in the product/work covered by this IFB are to be new and of suitable grade for the purpose intended. Brand or trade names referenced in specifications are for comparison purposes only. Bidders may submit Bids on items manufactured by other than the manufacturer specified when an "or equal" is stated.

26. Deviations to Specifications and Requirements

When bidding on an "or equal," Bids must be accompanied with all descriptive information necessary for an evaluation of the proposed material or equipment such as the detailed drawings and specifications, certified operation and test data, and experience records. Failure of any bidder to furnish the data necessary to determine whether the product is equivalent, may be cause for rejection of the specific item(s) to which it pertains. All deviations from the specifications must be noted in detail by the bidder on the Affidavit of Compliance form, at the time of submittal of Bid. The absence of listed deviations at the time of submittal of the Bid will hold the bidder strictly accountable to the specifications as written. Any deviation from the specifications as written and accepted by the City may be grounds for rejection of the material and/or equipment when delivered.

27. Samples (if required)

For certain types of procurements, samples may be required. If samples are required, it will be stated in the IFB. The following conditions and requirements apply to all samples submitted.

- a. The samples submitted by bidders on items for which they have received an award may be retained by the City until the delivery of contracted items is completed and accepted. Bidders whose samples are retained may remove them after delivery is accepted.
- b. Samples not retained must be removed as soon as possible after award has been made on the item or items for which the samples have been submitted. The City will not be responsible for such samples not removed by the bidder within 30 days after the award has been made. The City reserves the right to consume any or all samples for testing purposes.
- c. Bidders shall make all arrangements for delivery of samples to place designated as well as the removal of samples. Cost of delivery and removal of samples shall be borne by the bidder.
- d. All samples packages shall be marked "Sample for Division of Purchases" and each sample shall bear the name of the bidder, item number, Bid number, and shall be carefully tagged or marked in a substantial manner. Failure of the bidder to clearly identify samples as indicated may be considered sufficient reason for rejection of Bid.

28. Quality Guaranty

If any product delivered does not meet applicable specifications or if the product will not produce the effect that the bidder represents to the City, the bidder shall pick up the product from the City at no expense. Also, the bidder shall refund to the City any money which has been paid for same. The bidder will be responsible for attorney fees in the event the bidder defaults and court action is required.

29. Quality Terms

The City reserves the right to reject any or all materials if, in its judgment, the item reflects unsatisfactory workmanship, manufacturing, or shipping damages.

30. Tax-Exempt

The City is exempt from sales taxes and Federal Excise Taxes: Missouri Tax ID Number 12493651.

31. Awards

- a. *Unless otherwise stated in the Invitation for Bid, cash discounts for prompt payment of invoices will not be considered in the evaluation of prices. However, such discounts are encouraged to motivate prompt payment.*
- b. *As the best interest of the City may require, the right is reserved to make awards by item, group of items, all or none, or a combination thereof; to reject any and all Bids or waive any minor irregularity or technicality in Bids received.*
- c. *Awards will be made to the Bidder whose Bid (1) meets the specifications and all other requirements of the Invitation for Bid and (2) is the lowest and best Bid, considering price, delivery, responsibility of the bidder, and all other relevant factors.*

32. Authorized Product Representation

The successful bidder(s) by virtue of submitting the name and specifications of a manufacturer's product will be required to furnish the named manufacturer's product. By virtue of submission of the stated documents, it will be presumed by the City that the bidder(s) is legally authorized to submit and the successful bidder(s) will be legally bound to perform according to the documents.

33. Regulations

It shall be the responsibility of each bidder to assure compliance with OSHA, EPA, Federal, State of Missouri, and City rules, regulations, or other requirements, as each may apply.

34. Termination of Award

Any failure of the bidder to satisfy the requirements of the City shall be reason for termination of the award. Any Bid may be rejected in whole or in part for good cause when in the best interest of the City.

35. Royalties and Patents

The successful bidder(s) shall pay all royalties and license fees for equipment or processes in conjunction with the equipment being furnished. Bidder shall defend all suits or claims for infringement of any patent right and shall hold the City harmless from loss on account or cost and attorney's fees incurred.

36. Equal Employment Opportunity Clause

The City of Springfield, in accordance with the provision of Title VI of the Civil Rights Act of 1964 (78 Stat. 252) and the Regulations of the Department of Commerce (15 CFR, Part 8) issued pursuant to such Act, hereby notifies all bidders that affirmatively ensure that in any contract entered into pursuant to this advertisement that minority businesses will be afforded full opportunity to submit Bids in response to this advertisement and will not be discriminated against on the grounds of race, color, or national origin in consideration for award.

37. Bid Tabulation

Bidders may request a copy of the bid tabulation of the Invitation for Bid.

38. Budgetary Constraints

The City reserves the right to reduce or increase the quantity, retract any item from the Bid, or upon notification, terminate entire agreement without any obligations or penalty based upon availability of funds.

39. Additional Purchases by Other Public Agencies

The bidder by submitting a Bid authorizes other public agencies to "Piggy-Back" or purchase equipment and services being proposed in this Invitation for Bid unless otherwise noted on the Affidavit of Compliance Form.

40. Order of Precedence

Any and all Special/General Conditions and Specifications attached hereto, which varies from the instruction to bidders, shall take precedence.

41. Affidavit for Service Contracts

The Bidder represents, in accordance with RSMO 285.530.2 that they have not employed, or subcontracted with, unauthorized aliens in connection with the scope of work to be done under the IFB and agrees to provide an affidavit to the City of Springfield affirming that they have not, and will not in connection with the IFB, knowingly employ, or subcontract with, any person who is an unauthorized alien.

42. Inspection and Acceptance

No item(s) received by the City pursuant to this contract shall be deemed accepted until the City has had reasonable opportunity to inspect the item(s). Any item(s) which are discovered to be defective or which do not conform to any warranty of the Seller upon inspection may be returned at the seller's expense for full credit or replacement. If at a later time, the defects were not ascertainable upon the initial inspection may also be returned at the Seller's expense for full credit or replacement. The City's return of defective items shall not exclude any other legal, equitable or contractual remedies the City may have.

**CITY OF SPRINGFIELD
INVITATION FOR BID #115-2010
GENERAL TERMS AND CONDITIONS**

1. Services

The City agrees to engage the services of the Contractor and the Contractor agrees to perform the services in strict accordance with the specifications with the standard of care, skill and expertise ordinarily used by other members of contractor's profession in performing similar services.

2. Contract Documents

The agreement between the City of Springfield and the Contractor shall consist of (1) the Invitation for Bid, and any amendments thereto, and (2) the award letter. In the event of a conflict in language between the documents referenced above, the provisions and requirements set forth and/or referenced in the Invitation for Bid shall govern over all other documents. However, the City reserves the right to clarify any Contractual relationship in writing with the concurrence of the Contractor, and such written clarification shall govern in case of conflict with the applicable requirements stated in the Invitation for Bid. In all other matters not affected by the written clarification, if any, the Invitation for Bid shall govern. The Contractor is cautioned that the proposal shall be subject to acceptance without further clarification.

3. Modification of Contract

The work to be done under the Contract shall be subject to modification and supplementation upon the written agreement of the duly authorized representatives of the contracting parties. No provision in the Contract shall be changed or modified without the execution of a formal Change Order, mutually agreed to by the City and the Contractor and processed through the Division of Purchases. Upon request by the City, the Contractor shall provide an estimate of cost of any additional work or services to be incorporated by modification.

4. Exchange of Data

All information, data, and reports in the City's possession and necessary for the carrying out of the work, shall be furnished to the Contractor without charge, and the parties shall cooperate with each other in every way possible in carrying out the scope of services.

5. Personnel

a. The Contractor represents that Contractor will secure at Contractor's own expense, all personnel required to perform the services called for under this contract by Contractor. Such personnel shall not be employees of or have any contractual relationship with the City except as employees of the Contractor. All of the services required hereunder will be performed by the Contractor or under Contractor's direct supervision and all personnel engaged in the work shall be fully qualified and shall be authorized under state and local law to perform such services. None of the work or services covered by this contract shall be subcontracted without the written approval of the City.

b. The contractor represents, in accordance with RSMo statute Section 285.530.2, that it has not employed, or subcontracted with, unauthorized aliens in connection with the work to be done under the Contract and agrees to provide an affidavit to the City of Springfield affirming that it has not, and will not in connection with the Contract, knowingly employ, or subcontract with, any person who is an unauthorized alien.

6. Payment

Conditioned upon acceptable performance, the City agrees to pay the Contractor in accordance with the prices and terms for work authorized by City purchase order or other written notice by the City upon presentation of proper invoice and inspection by the City of work completed by the Contractor. The City expressly reserves the right to disapprove in whole or in part a request for payment where the services rendered during the period for which payment is claimed are not performed in a timely and satisfactory manner in accordance with the schedule and description of services.

7. Termination of Contract.

a. For Breach: If, through any cause, the Contractor shall fail to fulfill in a timely and proper manner Contractor's obligations under this contract, or if the Contractor shall violate any of the covenants, agreements, or stipulations of this contract, the City shall thereupon have the right to terminate this contract by giving written notice to the Contractor of such termination and specifying the effective date thereof, at least five (5) days before the effective day of such termination.

b. For Convenience: The City shall have the right at any time by written notice to Contractor to terminate and cancel this contract, without cause, for the convenience of the City, and Contractor shall immediately stop work.

In either such event, all finished or unfinished documents, data, studies, reports, or other materials prepared by the Contractor shall, at the option of the City become its property. The Contractor shall be entitled to receive just and equitable compensation for any satisfactory work completed prior to termination of the contract. Notwithstanding the above, the Contractor shall not be relieved of liability to the City for damages sustained by the City by virtue of any such breach of the contract by the Contractor.

8. Conflicts.

a. Contractor covenants that it presently has no interest and shall not acquire any interest, direct or indirect, which would conflict in any manner or degree with the performance of services to be performed under this contract. The Contractor further covenants that in the performance of this contract no person having such interest shall be employed.

b. No salaried officer or employee of the City and no member of the City Council shall have a financial interest, direct or indirect, in this contract. A violation of this provision renders the contract void. Any federal regulations and applicable provisions in Section 105.450 et seq. RSMo. shall not be violated.

9. Assignment

The Contractor shall not assign or transfer any interest in this contract (whether by assignment or novation), and shall not substitute any specific individuals and/or personnel qualifications without prior written consent of the City thereto. Provided, however, that claims for money due or to become due to the Contractor from the City under this contract may be assigned to a bank, trust company, or other financial institution without such approval. Notice of such assignment or transfer shall be furnished in writing promptly to the City. Any such assignment is expressly subject to all rights and remedies of the City under this agreement, including the right to change or delete activities from the contract or to terminate the same as provided herein, and no such assignment shall require the City to give any notice to any such assignee of any actions which the City may take under this agreement, though City will attempt to so notify any such assignee.

10. Confidentiality of Documents

Any reports, data, design or similar information given to or prepared or assembled by the Contractor under this contract which the City requests to be kept as confidential shall not be made available to any individual or organization by the Contractor without prior written approval of the City.

11. Discrimination

The Contractor agrees in the performance of this contract not to discriminate on the ground or because of race, creed, color, national origin or ancestry, sex, religion, handicap, age, or political opinion or affiliation, against any employee of Contractor or applicant for employment and shall include a similar provision in all subcontracts let or awarded hereunder.

12. Occupational License

The Contractor shall obtain and maintain an occupational license with the City of Springfield, Missouri, if required by city code and any required state or federal license. The cost for this occupational license shall be borne by the Contractor. No contract will be executed by the City until this occupational license has been obtained.

13. Compliance with Laws

Contractor agrees to comply with all applicable federal, state and local laws or rules and regulations applicable to the provision of services and products hereunder. Contractor affirmatively states that payment of all local, state, and federal taxes and assessments owed by Contractor is current.

14. Nonresident/Foreign Contractors

The Contractor shall procure and maintain during the life of this contract:

a. If the Contractor is a foreign corporation, a certificate of authority to transact business in the State of Missouri from the Secretary of State, unless exempt pursuant to the provisions of Section 351.572 RSMo.

b. A certificate from the Missouri Director of Revenue evidencing compliance with the transient employer financial assurance law, unless exempt pursuant to the provisions of Section 285.230 RSMo.

15. General Independent Contractor Clause

This agreement does not create an employee/employer relationship between the parties. It is the parties' intention that the Contractor will be an independent contractor and not the City's employee for all purposes, including, but not limited to, the application of the Fair Labor Standards Act minimum wage and overtime payments, Federal Insurance Contribution Act, the Social Security Act, the Federal Unemployment Tax Act, the provisions of the Internal Revenue Code, Missouri revenue and taxation laws, Missouri workers' compensation and unemployment insurance laws. The Contractor will retain sole and absolute discretion in the judgment of the manner and means of carrying out the Contractor's activities and responsibilities hereunder. The Contractor agrees that it is a separate and independent enterprise from the public employer, that it has a full opportunity to find other business, that it has made its own investment in its business, and that it will utilize a high level of skill necessary to perform the work. This agreement shall not be construed as creating any joint employment relationship between the Contractor and the City, and the City will not be liable for any obligation incurred by the Contractor, including but not limited to unpaid minimum wages and/or overtime premiums.

16. City Benefits The Contractor shall not be entitled to any of the benefits established for the employees of the City nor be covered by the Worker's Compensation Program of the City.

17. Liability and Indemnity The parties mutually agree to the following:

a. In no event shall the City be liable to the Contractor for special, indirect, or consequential damages, except those caused by the City's gross negligence or willful or wanton misconduct arising out of or in any way connected with a breach of this contract. The maximum liability of the City shall be limited to the amount of money to be paid or received by the City under this contract.

b. The Contractor shall defend, indemnify, and hold harmless the City, its elected or appointed officials, agents and employees, from and against any and all liability, suits, damages, costs (including attorney fees), losses, outlays and expenses from claims in any manner caused by, or allegedly caused by, or arising out of or connected with, this contract, or the work of any subcontract there under (the Contractor or hereby assuming full responsibility for relations with subcontractors), including but not limited to claims for personal injuries, death, property damage, or for damages from the award of this contract to Contractor.

c. The Contractor shall indemnify and hold the city harmless from all wages or overtime compensation due any employees in rendering services pursuant to this agreement or any subcontract, including payment of reasonable attorneys' fees and costs in the defense of any claim made under the Fair Labor Standards Act, the Missouri Prevailing Wage Law or any other federal or state law.

18. Insurance

Contractor shall secure and maintain, at its own cost and expense and at all times during the term of the contract, adequate insurance of such types and in such amounts as may be necessary to protect it and the interests of the City of Springfield against all hazards or risks of loss as hereunder specified or which may arise out of the performance of the contract documents. The form and limits of such insurance, together with the underwriter thereof in each case, are subject to approval by the City of Springfield. Failure of the Contractor to maintain coverage shall not relieve it of any contractual responsibility or obligation or liability under the contract documents.

The certificates of insurance, including evidence of the required endorsements hereunder or the policies, shall be filed with the City of Springfield within ten (10) days of the date of receipt of the Award of the contract to the Contractor, and prior to the start of work. All insurance policies shall provide thirty (30) days written notice to be given by the insurance company in question prior to modification or cancellation of such insurance. Such notices shall be mailed, certified mail, return receipt requested, to:

Jim Tillman, Purchasing Agent
City of Springfield
218 E Central
Springfield, MO 65802; and

Such policies shall name the City as an additional named insured with limits of liability not less than the sovereign immunity limits for Missouri public entities calculated by the Missouri Department of Insurance as of January 1 each calendar year and published annually in the Missouri Register pursuant to Section 537.610, RSMo. (See, [HTTP://insurance.mo.gov/industry/sovimmunity.htm](http://insurance.mo.gov/industry/sovimmunity.htm)) as follows:

As of January 1, 2010, the minimum coverage for the insurance referred to herein shall be as set out below:

a. Workers' Compensation....Statutory coverage per RSMo 287.010 et seq

Employer's Liability..... \$1,000,000.00

b. Commercial General Liability Insurance, including coverage for Contractual Liability and Independent Contractors Liability. Such coverage shall apply to bodily injury and property damage on an "Occurrence Form Basis" with limits of at least **Two Million Five Hundred Nine Thousand One Hundred Eighty Six Dollars (\$2,509,186.00)** for all claims arising out of a single accident or occurrence and at least **Three Hundred Seventy Six Thousand Three Hundred Seventy Eight Dollars (\$376,378.00)** with respect to injuries and/or death of any one person in a single occurrence and an amount not less than at least \$1,000,000 for all claims to property arising out of a single occurrence and at least \$100,000 to any one owner with respect to damages to property.

c. Automobile Liability Insurance covering bodily injury and property damage for owned, non-owned and hired vehicles, with limits of at least **Two Million Five Hundred Nine Thousand One Hundred Eighty Six Dollars (\$2,509,186.00)** for all claims arising out of a single accident or occurrence and at least **Three Hundred Seventy Six Thousand Three Hundred Seventy Eight Dollars (\$376,378.00)** with respect to injuries and/or death of any one person in a single accident or occurrence.

d. Builders Risk Insurance for contracts involving unoccupied structures. The Contractor shall secure "All Risk" Builders Insurance. Unless specifically authorized by the City, the amount of such insurance shall not be less than the total contract price. The policy shall name as insured the Contractor and the City of Springfield.

e. Subcontracts. In case any or all of this work is sublet, the Contractor shall require the subcontractor to procure and maintain all insurance required in subparagraphs (a), (b) and (c) hereof and in like amounts. Contractor shall require any and all subcontractors with whom it enters into a contract to perform work on this project to protect the City of Springfield through insurance against applicable hazards or risks and shall, upon request of the City, provide evidence of such insurance.

f. Legislative or Judicial Changes. In the event the scope or extent of the City's tort liability as a governmental entity as described in Section 537.600 through 537.650 RSMo is broadened or increased during the term of this agreement by legislative or judicial action, the City may require Contractor, upon 10 days written notice, to execute a contract addendum whereby the Contractor agrees to provide, at a price not exceeding Contractor's actual increased premium cost, additional liability insurance coverage as the City may require to protect the City from increased tort liability exposure as the result of such legislative or judicial action. Any such additional insurance coverage shall be evidenced by an appropriate certificate of insurance and shall take effect within the time set forth in the addendum.

19. Notices

All notices required or permitted hereinunder and required to be in writing may be given by FAX or by first class mail addressed to City or Contractor. The date of delivery of any notice given by mail shall be the date falling on the third day after the day of its mailing. The date of delivery of notice by FAX transmission shall be deemed to be the date transmission occurs, except where the transmission is not completed by 5:00 p.m. on a regular business day at the terminal of the receiving party, in which case the date of delivery shall be deemed to fall on the next regular business day for the receiving party.

20. Jurisdiction

This agreement and every question arising hereunder shall be construed or determined according to the laws of the State of Missouri. Should any part of this agreement be litigated, venue shall be proper only in the Circuit Court of Greene County, Missouri.

21. Entire Agreement

This agreement contains the entire agreement of the parties. No modification, amendment, or waiver of any of the provisions of this agreement shall be effective unless in writing specifically referring hereto, and signed by both parties.

22. Contractor's Responsibility for Subcontractors

It is further agreed that Contractor shall be as fully responsible to the City for the acts and omissions of its Subcontractors, and of persons either directly or indirectly employed by them, as Contractor is for the acts and omissions of persons it directly employs. Contractor shall cause appropriate provisions to be inserted in all subcontracts relating to this work, to bind all Subcontractors to Contractor by all the terms herein set forth, insofar as applicable to the work of Subcontractors and to give Contractor the same power regarding termination of any subcontract as the City may exercise over Contractor under any provisions of this contract. Nothing contained in this contract shall create any contractual relation between the Subcontractor and the City or between any Subcontractors

23. Waiver

No provision of the contract documents shall be construed, expressly or by implication, as a waiver by the City of any existing or future right or remedy available by law in the event of any claim of default or breach of contract.

24. Prevailing Wages

All labor utilized in the construction of the aforementioned improvements shall be paid a wage of no less than the "prevailing hourly rate of wages" for work of a similar character in this locality, as established and amended at any time by the Department of Labor and Industrial Relations of the State of Missouri. At any time the contractor is found to not have paid prevailing wages, the contractor shall forfeit as a penalty to the city one hundred dollars for each underpaid worker employed, for each calendar day, or portion thereof such worker is paid less than the said stipulated rates for any work done under this contract.

25. New Products

All Items offered under this Invitation for Bid shall be new.

26. Pre-Bid Site Visit

The contractor shall be presumed to have made a reasonable inspection of the premises prior to the time of bidding and shall be held responsible for all information available through such inspection. The contractor shall immediately upon discovery, bring to the attention of the owner any conflicts that may occur among the various provisions of the specifications. The owner shall resolve such conflicts and shall be responsible for any costs reasonably incurred by the contractor due to such conflict. Failure of the contractor to bring conflicts or exceptions to the attention of the owner shall allow the owner to require any change deemed necessary before acceptance by the owner. A **pre-bid site visit** will be held for this bid on **April 14, 2010 at 9:00 am** at Fire Station #12 located at 2431 South Blackman Road, Springfield, MO 65809.

27. Bid Guaranty

No Bid Guaranty is required for this project.

28. Payment Terms

The Bidder shall clearly state their prompt payment discount and net payment terms in their proposal. If the Bidder does not provide this information, the City will assume terms are net 30 days.

29. Repair of Damages

It is the responsibility of the Contractor to repair any damages incurred in the area that is directly related to the project. When damages occur, the City of Springfield's Representative is to be notified and shall inspect the repairs upon completion.

30. Safety

Contractor shall comply with all applicable OSHA, State of Missouri Safety Regulations and comply with all construction safety requirements of local authorities having jurisdiction. Contractor shall exercise all due caution to exclude the public from the work area and especially from contact with any hazardous materials.

31. Site Cleanliness

The Contractor shall give special attention to keeping the work site clean and free from trash and debris. Trash, debris and waste materials shall not be left at the customer's premises, but shall be disposed of at the Contractor's facilities.

32. Delays

If the Contractor or his subcontractor experiences documented hindrances or delays which, in his opinion, are not usually to be expected in the performance of the work, and which affect the performance of the work, he may request a change in the agreement. The Contractor shall be entitled to an extension of the time for contract completion, but such contract time of completion shall be extended no more than one day for each day of delay. Any such agreement to modify or extend the time of contract completion shall be made in writing by formal addendum to the contract. The time of application of liquidated damages shall not begin until after the amended date for contract/phase completion. Such hindrances and delays may include, but not be limited to, acts or failures to act by other contractors employed by the City, fires, floods, labor disputes, epidemics, abnormal weather conditions, or acts of God.

33. Punch List

A list of incomplete items (typically referred to as a "punch list") will be issued at Substantial Completion provided that no incomplete item will prevent the Owner's use of the space/facility as it is intended to be used, including life safety components. After Substantial Completion and issuance of the "punch list", subsequently discovered items which are not complete, and/or in nonconformance with the Contract may be added to the list until such time as Final Acceptance. Payment and/or exclusion of any item from a "punch list" shall not relieve the Contractor of the obligation to fulfill all requirements of the Contract. All punch list items shall be completed within thirty (30) days of Final Acceptance by the City and prior to final payment.

34. Protection of Work

The Contractor shall continuously maintain adequate protection of all his work from damage and shall protect from injury or loss arising in connection with the contract. He shall make good any such damage, injury, or loss, except as such may be directly due to error in Contract documents.

35. Liquidated Damages

Should the Contractor fail to complete work under this contract on or before the date stipulated for completion or such later date as may result from extension time granted by the City, the Contractor and Contractor's Surety, if any, shall pay the City as liquidated damages, the sum of **\$200.00** for each consecutive calendar day that terms of the contract remain unfulfilled beyond the date allowed by the contract, which sum is agreed upon as reasonable and proper measure of damages which the City will sustain per diem by failure of Contractor to complete work within time as stipulated; it being recognized by the City and Contractor to complete on schedule is uncertain and cannot be computed exactly. In no way shall costs for liquidated damages be construed as a penalty on the Contractor.

36. Prevailing Wage Notice of Excessive Unemployment in Effect as of October 19, 2007

Only Missouri laborers and laborers from nonrestrictive states are allowed by law to be employed on Missouri's public works projects when the unemployment rate exceeds 5% for two consecutive months. (See Sections 290.550 through 290.580 RSMo.) The unemployment rate has exceeded 5% for the past two months. Therefore, this statute is in effect and will remain in effect as long as this notice is posted. For questions call (573) 751-3403. View the Frequently Asked

Questions at http://www.labor.mo.gov/ls/faq/faq_PublicWorksEmployment.asp or view the statute 290.550 – 290.580 RSMo, at <http://www.moga.mo.gov/statutes/C290.HTM>.

Restrictive states are as follows: Alaska, Arizona, California, Colorado, Connecticut, Delaware, District of Columbia, Florida, Idaho, Illinois, Iowa, Maine, Massachusetts, Mississippi, Montana, Nevada, New Jersey, North Dakota, Oklahoma, South Dakota, U.S. Virgin Islands, West Virginia and Wyoming.

37. Performance Bond and a Labor, and Materials Payment Bond

The Contractor shall furnish a Performance Bond and a Labor and Materials Payment Bond with surety approved by the City and on the forms approved by the City, each bond shall be in the full amount of the contract conditioned upon the full and faithful performance of all major terms and conditions of this contract and payment of all labor and material suppliers. It is further mutually agreed between the parties hereto that if at any time after the execution of this agreement and the surety bond(s) hereto attached for its faithful performance and payment of labor and material suppliers, the City shall deem the surety or sureties upon such bond(s) to be unsatisfactory, or if, for any reason, such bond(s) ceases to be adequate to cover the performance of the work, the Contractor shall, at its expense, within five (5) days after the receipt of notice from the City to do so, furnish an additional bond or bonds, in such form and amount, and with such surety or sureties as shall be satisfactory to the City. In such event no further payment to the Contractor shall be deemed to be due under this contract until such new or additional security for the faithful performance of the work and the payment of labor and material suppliers shall be furnished in a manner and form satisfactory to the City. The corporate surety on any performance or payment bond must be licensed by the State of Missouri and if the required bond exceeds \$25,000 must be listed in United States Treasury Circular 570.

38. Permits

All permits necessary for the prosecution of the work shall be secured and paid for by the Contractor. The Contractor shall give all notices and comply with all laws, ordinances and regulations bearing on the conduct of the work (as specified).

39. Basis for Award

Other factors that will be considered besides the lowest price are:

- a.. Contractors completion time as specified in their bid

The contract resulting from this Invitation for Bid will be awarded to that responsible offeror whose offer, conforming to the invitation is determined most advantageous to the City of Springfield, price and other factors considered.

**CITY OF SPRINGFIELD
INVITATION FOR BID #115-2010
SPECIFICATIONS**

1. Scope

The City of Springfield is requesting bids for the removal, purchase and installation of overhead doors at Fire Station #12, located at 2431 South Blackman Road, Springfield, MO 65809. The successful offeror shall be required to provide all labor to remove without damaging the six (6) existing overhead doors including tracks, cables, etc for disposition by the City. The offeror shall also provide all labor and materials to modify six (6) mounting jambs to facilitate the correct installation of six (6) new overhead doors utilizing existing operators.

2. Manufacturer

A. Sectional Overhead Doors shall be equal to Overhead Door Corporation – Series 422 Insulated Steel Sectional Doors.

B. Subject to compliance with requirements, additional manufacturers offering products which may be incorporated in the work include:

1. Atlas Door Corp.
2. Windsor Door Division; Ceco Corporation.

3. Insulated Steel Sectional Doors

A. Doors shall be equal to the 595 Series Thermacore Insulated Steel Sectional Doors by Overhead Door Corporation.

B. Sectional Door Assembly: Insulated steel door assembly with rabbeted meeting rails to form weathertight joints and provide full-width interlocking structural rigidity. Units shall have the following characteristics:

1. Panel Thickness: 2 inches.
2. Exterior Surface: Flush Panel, textured finish.
3. Steel: Minimum 20 gauge galvanized exterior, back cover 26 gauge steel, (poly-backer).
4. Center and End Stiles: 16 gauge.
5. Standard Springs: 10,000 cycles (High cycles).
6. Insulation: HCFC-free Polystyrene, R-value 7.35.
7. Lites as shown on drawings with insulated double strength glass, tinted, color same as glazing in building windows. Provide manufacturer's standard panel at lite sections as required to accommodate glazed opening with thermal insulated glass. Lite panel sections shall match finish of other panels with no perception differences.
8. Provide manufacturer's optional high-usage components.

C. Finish and Color: Factory-applied baked-on finish, color to be White

D. Windload Design: ANSI/DASMA 102 standards and as required by code. Minimum 20 lbs per square foot.

E. Hardware: Galvanized steel hinges and fixtures. Ball bearing rollers with hardened steel races.

F. Lock: Interior mounted slide lock operator controls.

G. Weatherstripping: Flexible PVC on bottom section (Header seal and jamb weatherstripping for fully weather tight installation).

H. Track: Provide lift clearance track – low headroom track as recommended by manufacturer to suit loading required and clearances available. Doors track shall be mounted so that doors “follow the roof” and raise as high as possible against structure. Provide complete track assembly as required for size and weight of door assembly to ensure against sag, sway or excessive vibration during door operation.

I. Entrapment Protection: (Pneumatic sensing edge up to 18 inches wide).

J. Provide hand-operated disconnect or mechanism for automatically engaging sprocket chain operator and releasing brake for emergency manual operation.

K. Provide glazed sections as shown on drawings, glass shall be insulated tinted to match glazing at windows.

4. Installation

A. Install door, track and operating equipment complete with necessary hardware, jam and head mold stops, anchors, inserts, hangers, and equipment supports.

B. Fasten vertical track assembly to framing at not less than 24 inches o.c. Hang horizontal track from structural overhead framing with angle or channel hangers, welded and bolt-fastened in place. Provide sway bracing, diagonal bracing, and reinforcing as required for rigid installation of track and door operating equipment.

C. Provide miscellaneous supports at wall construction as required for installation of door and operating equipment to ensure door operates correctly.

D. Upon completion of installation, lubricate, test and adjust doors to operate easily, free from warp, twist, or distortion and fitting weathertight for entire perimeter.

5. Warranty

A. Doors should be warranted for Materials, Labor and Travel for a minimum of one year from installation.

6. Optional door/hardware upgrade

Contractors shall submit a total price to upgrade the above overhead doors specifications with these specifications. These specification shall supersede those of same or similar listed above.

1. Manufacturer: Overhead Door Corporation or Equal, 595 series “Thermacore” sectional door
2. Section Thickness: 1 5/8 inches with all sections to be fitted with tube seal to weatherstrip each joint.
3. Exterior Surface: Flush Panel, textured finish.
4. Steel: Minimum 20 gauge roll-formed hot dipped galvanized, flush textured faced steel exterior sections, with metal/foam/metal sandwich, foamed-in-place homogeneous CFC/HCFC free polyurethane insulation. Polyurethane insulation to be fully encapsulated in non-permeable materials for no loss of thermal efficiency
5. Center and End Stiles: 16 gauge steel; hinges and fixtures shall be galvanized steel.
6. Standard Springs: 100,000 cycles (High cycles).
7. Insulating values: R = 14.86, U = .67.
8. Lites as shown on drawings with insulated double strength glass, tinted, color same as glazing in

building windows. Provide manufacturer’s standard panel at lite sections as required to accommodate glazed opening with thermal insulated glass. Lite panel sections shall match finish of other panels with no perception differences.

9. EPDM thermal break to be provided between interior and exterior skins to prevent thermal Transmission.
10. Water channel to provide for a drip free opening.
11. Doors to be designed to meet or exceed industry standards for wind loading. Air infiltration of .08 cfm per square foot of door at 15 mph, and class 26 sound transmission.
12. Minimum of 10 year limited warranty against delamination of foam and steel skins.

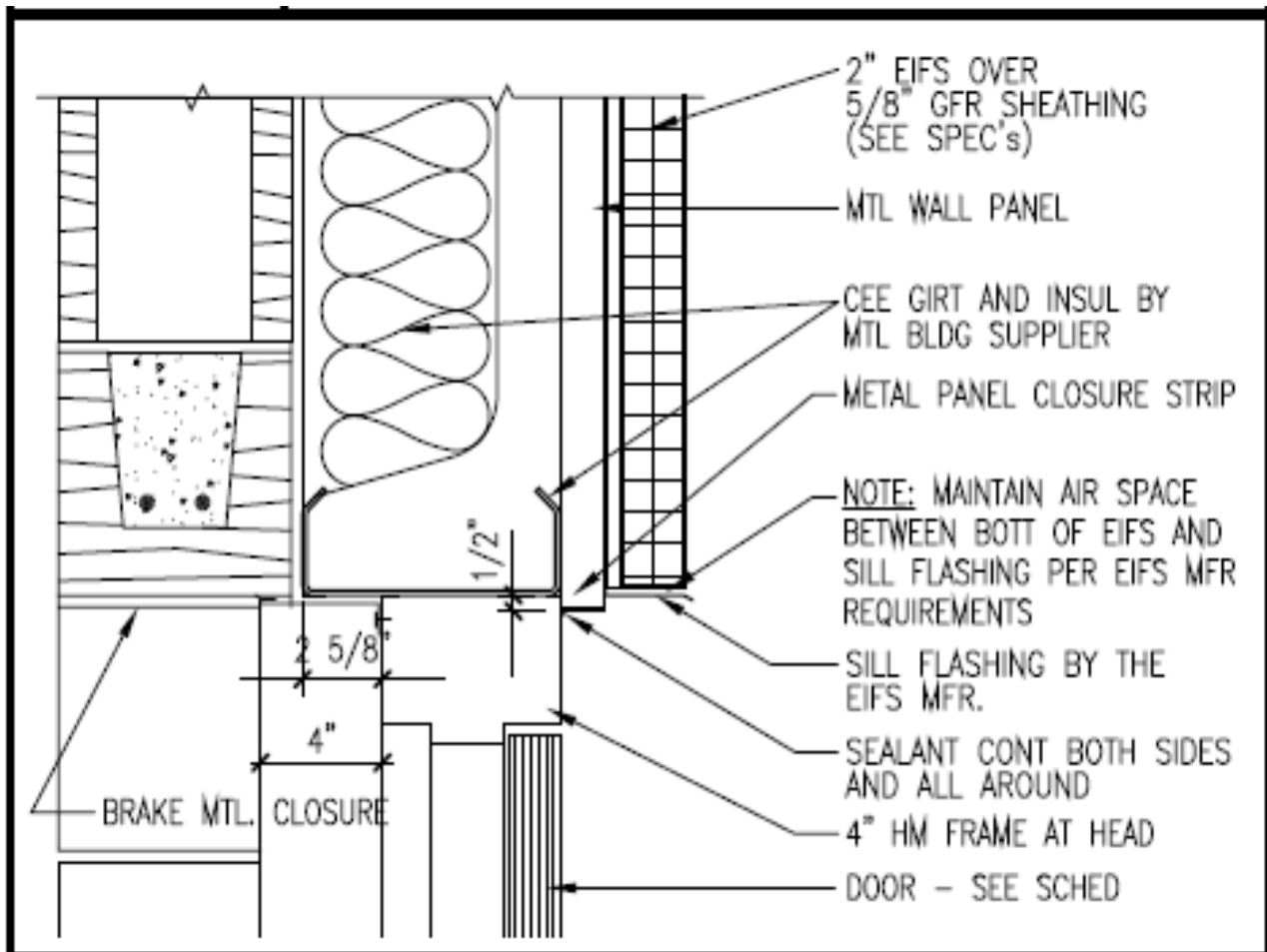

18

HEAD DETAIL

1 1/2"=1'-0"

EXTERIOR HM DOOR AT EIFS

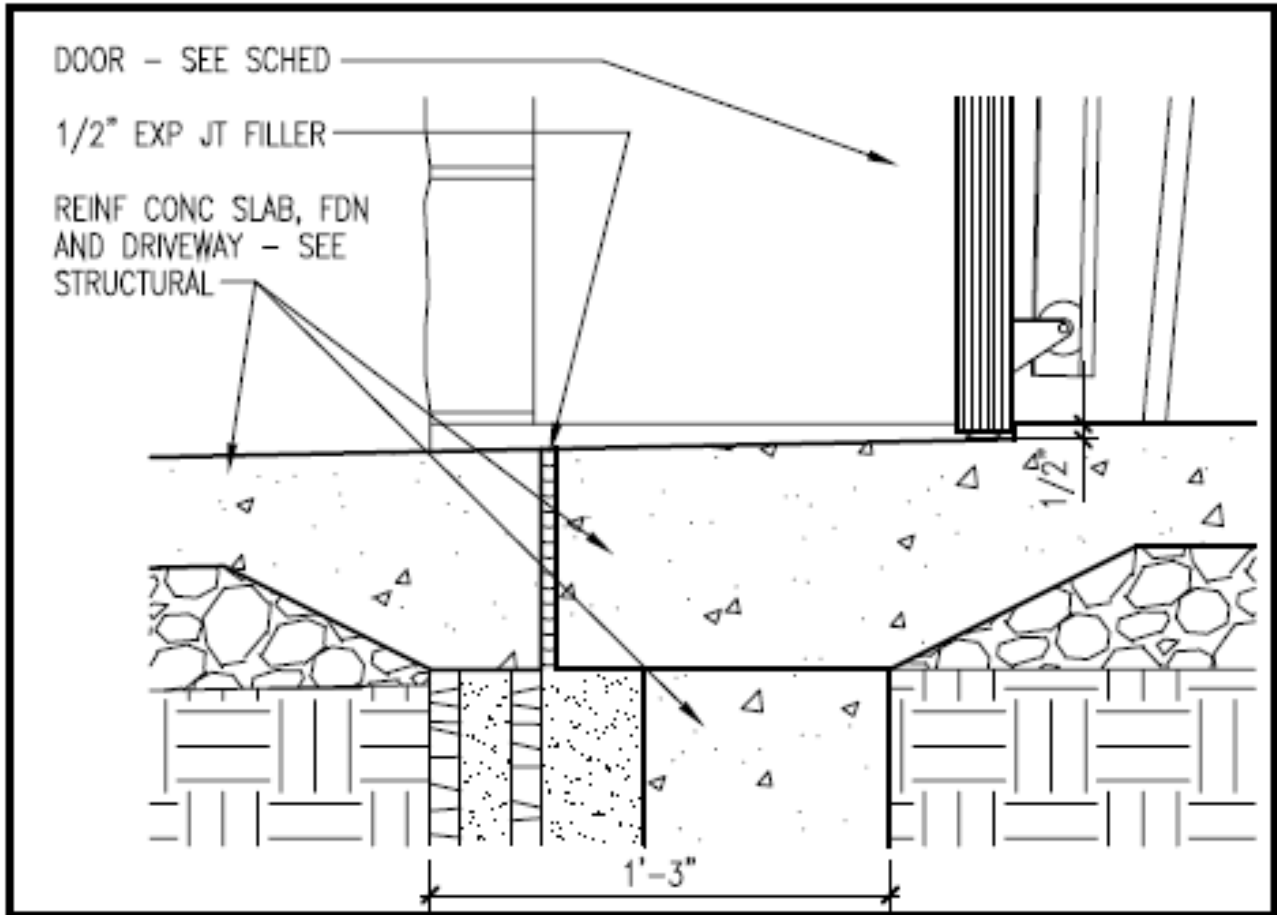

19	THRESHOLD DETAIL
1 1/2"=1'-0"	AT OVERHEAD DOOR

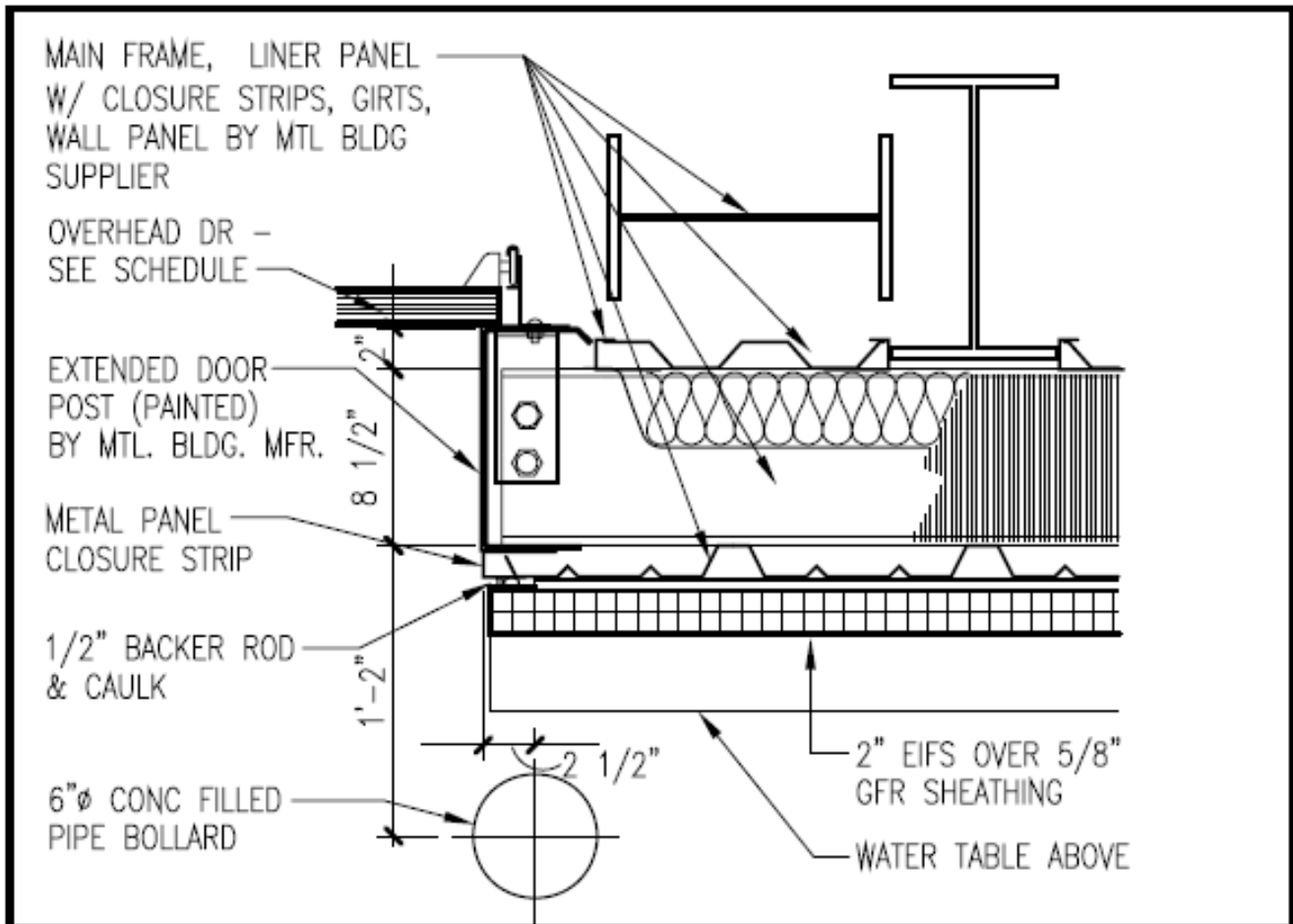

20	JAMB DETAIL
-----------	--------------------

1"=1'-0"	AT OVERHEAD DOOR AND EIFS
----------	---------------------------

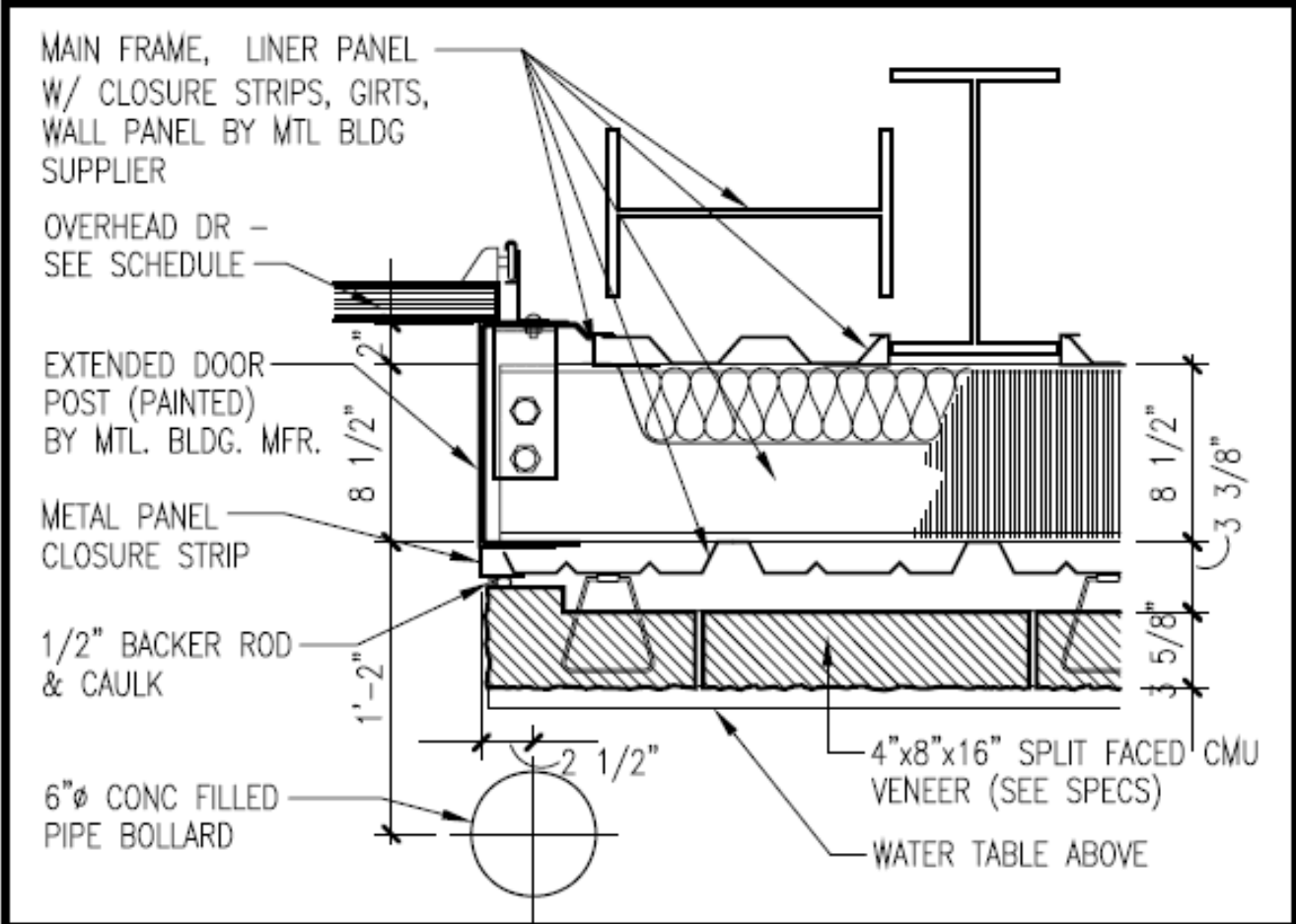

21	JAMB DETAIL
1"=1'-0"	AT OVERHEAD DOOR AND MASONRY WAINSCOT

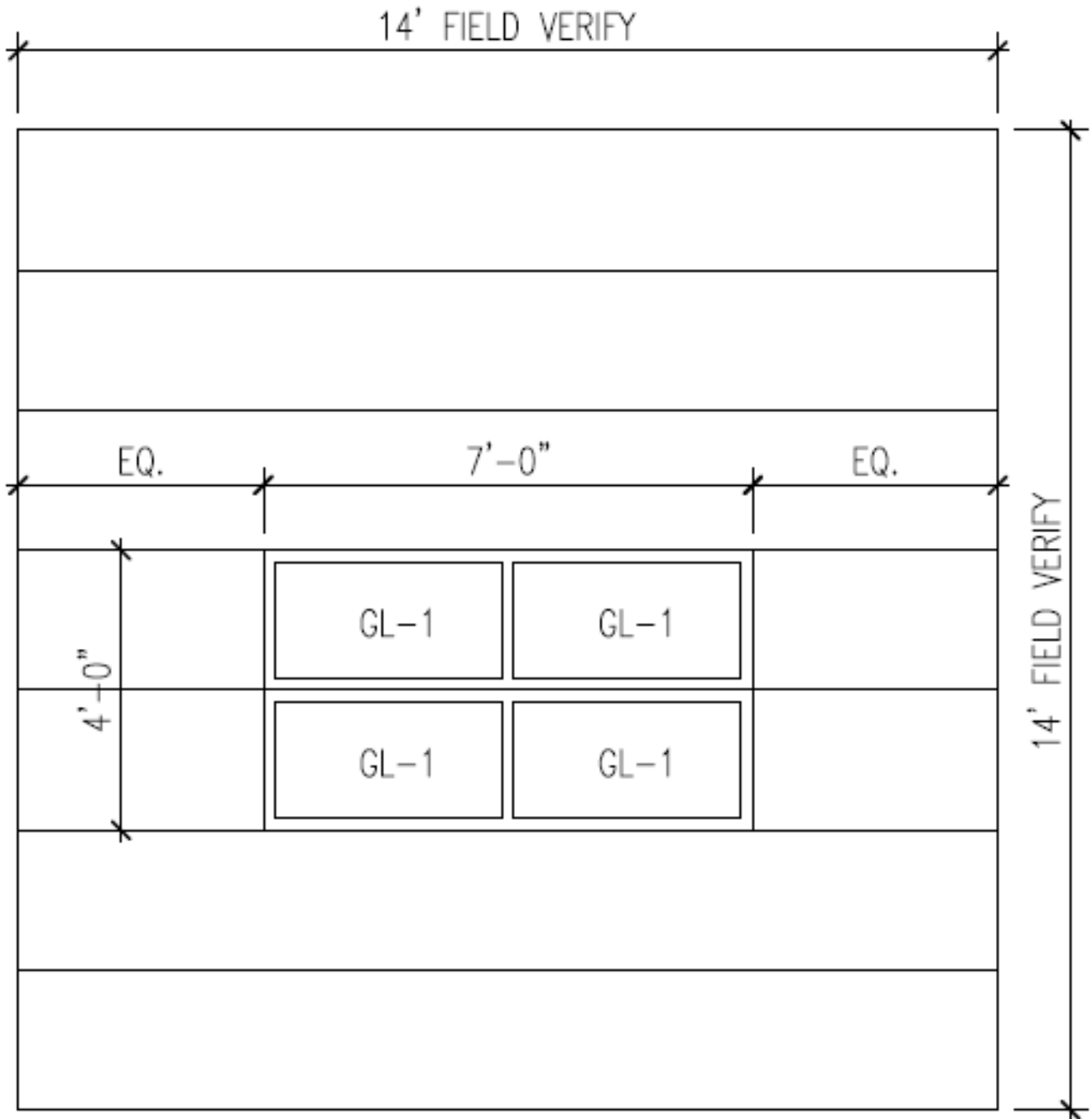

E

OVERHEAD SECTIONAL
 PREFINISHED, INSULATED.

PERFORMANCE BOND

KNOW ALL MEN BY THESE PRESENTS that _____ as principal and _____, as surety are held and firmly bound to the City of Springfield, Missouri, in the sum of _____ Dollars (_____) to be paid to the City of Springfield, Missouri, and for the lawful payment of said sum we, and each of us, hereby bind ourselves, our heirs, our executors, administrators, successors and assigns firmly by these presents,

The condition of this bond is such that:

WHEREAS the above-named principal did on the _____ day of _____, 2010, enter into a contract with the City of Springfield, Missouri, for:

TURN-KEY OVERHEAD DOOR REPLACEMENT PER IFB # 115-2010

NOW, THEREFORE, if the above-named principal shall well and truly:

Keep and perform all of the contract on his, hers, its or their part to be kept and performed, and faithfully comply with all of the laws of the State of Missouri and all the ordinances of the City of Springfield, Missouri, applicable to the aforesaid contract and this bond and the conditions of said contract, and at the time stipulated in said contract or within a reasonable time if not time as stipulated;

Then this obligation shall be void, otherwise it shall remain in full force and effect.

It is understood and agreed that this bond shall not be avoided because of changes in the plans or specifications for the work, or because of extensions of time for the performance of work, and the surety above-named does hereby waive notice of and does hereby consent to any such changes or extensions of time.

The principal and surety specifically hereby grant authority to the City of Springfield, Missouri, and hereby request the City to date this bond consistent with the date of the contract upon signature of the contract by the City.

In addition to any other remedies which may be had by the City of Springfield, Missouri, under this bond, the City may in case of default or abandonment of the contract hereinbefore referred to notify the surety hereto by registered or certified mail directed to the surety or to its attorney-in-fact for it authorized at the time of the execution of this bond that such default or abandonment has occurred, which such notice need not be detailed but may be in generalities, and the surety shall have the obligation to inquire into the nature of such default or abandonment and to thereafter within sixty (60) days from the date of such notice proceed toward completion without undue delay of the improvement in accordance with the contract aforesaid; and in the event of default on the part of the surety to proceed to complete as aforesaid the City of Springfield, Missouri, shall have the right to itself complete the work, and upon completion to be reimbursed by the principal, the surety or both of them for the cost of said completion including cost of re-advertisements, preparation of new plans, contracts, and all other ordinary and reasonable expenses in connection with completion of the work.

This bond shall be governed by the laws of the State of Missouri. The parties hereto agree that should any litigation arise out of this bond, the venue for such litigation shall be in the Circuit Court of Greene County, Missouri, and the parties hereto expressly waive all rights to venue inconsistent therewith.

IN WITNESS WHEREOF, we have hereunto set our hands and seals this _____ day of _____, 2010, or have caused these presents to be executed by our authorized agent on the same day and year.

Company: _____

Approved as to Form:

By: _____

Assistant City Attorney

Surety: _____

By: _____

PAYMENT BOND FOR LABOR AND MATERIALS

KNOW ALL MEN BY THESE PRESENTS that _____ as principal and _____, as surety are held and firmly bound to the City of Springfield, Missouri, in the sum of _____ Dollars (_____) to be paid to the City of Springfield, Missouri, and for the lawful payment of said sum we, and each of us, hereby bind ourselves, our heirs, our executors, administrators, successors and assigns firmly by these presents,

The condition of this bond is such that:

WHEREAS the above-named principal did on the _____ day of _____, 2010, enter into a contract with the City of Springfield, Missouri, for:

TURN-KEY OVERHEAD DOOR REPLACEMENT PER IFB # 115-2010

NOW, THEREFORE, if the above-named principal shall well and truly:

Pay for any and all materials, lubricants, oil, gasoline, grain, hay, feed, coal and coke, repairs on machinery, groceries and foodstuffs, equipment and tools consumed or used in connection with the construction of the work aforescribed, and all insurance premiums both for compensation and for all other kinds of insurance on said work above described, and for all labor performed in the work whether by the principal or by subcontractor or otherwise and at the prevailing hourly rate of wages made applicable to the work as specified by the contract (if a prevailing hourly rate of wages shall have been so specified).

Then this obligation shall be void, otherwise it shall remain in full force and effect.

It is understood and agreed that this bond is executed and furnished under the provisions of Section 2.5 of the Springfield City code.

It is understood and agreed that this bond shall not be avoided because of changes in the plans or specifications for the work, or because of extensions of time for the performance of work, and the surety above-named does hereby waive notice of and does hereby consent to any such changes or extensions of time.

The principal and surety specifically hereby grant authority to the City of Springfield, Missouri, and hereby request the City to date this bond consistent with the date of the contract upon signature of the contract by the City.

It is understood and agreed that any person entitled to payment for any of the matters upon which this bond is conditioned shall have the right in his name or in the name of the City of Springfield, Missouri, to bring suit upon this bond for the recovery of such payment. It is further agreed that no such suit shall be instituted after the expiration of ninety (90) days from the completion of the contract hereinbefore referred to unless otherwise provided by of Section 2.5 (d) of the Springfield City Code.

This bond shall be governed by the laws of the State of Missouri. The parties hereto agree that should any litigation arise out of this bond, the venue for such litigation shall be in the Circuit Court of Greene County, Missouri, and the parties hereto expressly waive all rights to venue inconsistent therewith.

IN WITNESS WHEREOF, we have hereunto set our hands and seals this _____ day of _____, 2010, or have caused these presents to be executed by our authorized agent on the same day and year.

Company: _____

Approved as to Form:

By: _____

Assistant City Attorney

Surety: _____

By: _____

Notice and Instructions to Bidders/Vendors

Regarding Sections 285.525 through 285.550 RSMO, Effective January 1, 2009 and Section 292.675 RSMO, Effective August 28, 2009

Effective January 1, 2009 and pursuant to the State of Missouri's RSMO 285.530 (1), No business entity or employer shall knowingly employ, hire for employment, or continue to employ an unauthorized alien to perform work within the state of Missouri.

As a condition for the award of any contract or grant in excess of five thousand dollars by the state or by any political subdivision of the state (e.g., Greene County, Mo.) to a business entity, the business entity (Company) shall, by sworn affidavit and provision of documentation, affirm its enrollment and participation in a federal work authorization program with respect to the employees working in connection with the contracted services. Every such business entity shall sign an affidavit affirming that it does not knowingly employ any person who is an unauthorized alien in connection with the contracted services. [RSMO 285.530 (2)]

RSMO 285.530 pertains to all solicitations for services over \$5,000. RSMO 285.530 does not apply to solicitations for goods only. If a solicitation is for services and goods, RSMO 285.530 applies if the services portion of the solicitation is over \$5,000.

Effective August 28, 2009 and pursuant to the State of Missouri's RSMO 292.675, Contractors and subcontractors who sign a contract to work on public works projects must provide a 10-hour OSHA construction safety program, or similar program approved by the Department of Labor and Industrial Relations, to be completed by their on-site employees within sixty (60) days of beginning work on the construction project. Contractors and subcontractors in violation of this provision will forfeit to the public body \$2,500 plus \$100 a day for each employee who is employed without training. Public bodies and contractors may withhold assessed penalties from the payment due to those contractors and subcontractors.

In order to comply with sections 285.525 through 285.550 and 292.675 RSMO, City requires the following bid and contract documents:

1. Affidavit for Service Contracts over \$5,000.00 (US) – Effective 1-1-2009, Company shall comply with the provisions of Section 285.525 through 285.550 R.S.Mo. Contract award is contingent on Company providing an acceptable notarized affidavit stating:

- a. that Company is enrolled in and participates in a federal work authorization program with respect to the employees working in connection with the contracted services; and
- b. that Company does not knowingly employ any person who is an unauthorized alien in connection the contracted services.

2. Affidavit for any Public Works Project Contract – Effective 8-28-2009, Company shall comply with the provisions of Section 292.675 R.S.Mo. Within 60 days of issuance of Notice to Proceed, Company shall provide an acceptable notarized affidavit stating that Company has verified the completion of a 10-hour construction safety program with respect to the employees working in connection with the contracted services.

3. Additionally, Company must provide documentation evidencing current enrollment in a federal work authorization program (e.g. electronic signature page from E-Verify program's Memo of Understanding (MOU). *See attached sample*

The City of Springfield encourages companies that are not already enrolled and participating in a federal work authorization program to do so. E-Verify is an example of this type of program. Information regarding E-Verify is available at http://www.dhs.gov/xprevprot/programs/gc_1185221678150.shtm or by calling **888-464-4218**.

If you have any questions, please contact the City Purchasing Department at 417- 864-1620.

**Affidavit of Compliance with Section 285.500, RSMo., et seq.
For All Agreements Providing Services In Excess Of \$5,000.00.**

Effective January 1, 2009

STATE OF _____)

) ss.

COUNTY OF _____)

Before me, the undersigned Notary Public, in and for the County of _____,

State of _____, personally appeared _____ (Name)

who is _____ (Title) of _____

(Name of company), a (circle one) corporation, partnership, sole proprietorship, limited liability company, and is competent and authorized to make this affidavit, and being duly sworn upon oath deposes and says as follows:

(1) that said company is enrolled in and participates in a federal work authorization program with respect to the employees working in connection with the contracted services; and

(2) that said company does not knowingly employ any person who is an unauthorized alien in connection with the contracted services.

The terms used in this affidavit shall have the meaning set forth in Section 285.500 R.S.Mo., et seq.

Documentation of participation in a federal work authorization program is attached to this affidavit.

Signature

Print Name: _____

Subscribed and sworn to before me this _____ day of _____, _____.

Notary Public

My commission expires: _____

Affidavit of Compliance with Section 292.675 R.S.Mo., Et Seq.
For Any Public Works Project Contract
Effective August 28, 2009

STATE OF _____)

) ss.

COUNTY OF _____)

Before me, the undersigned Notary Public, in and for the County of _____,

State of _____, personally appeared _____ (*Name*)

who is _____ (*Title*) of _____

(*Name of company*), (a corporation), (a partnership), (a sole proprietorship), (a limited liability company), and is competent and authorized to make this affidavit, and being duly sworn upon oath deposes and says as follows:

- (1) that said company has verified the completion of a 10-hour construction safety program with respect to the employees working in connection with the contracted services.

The terms used in this affidavit shall have the meaning set forth in Sections 292.675 R.S.Mo., et seq.

Signature

Name: _____

Subscribed and sworn to before me this _____ day of _____, _____.

Notary Public

My commission expires: _____

Company ID Number: XXXXXX

The foregoing constitutes the full agreement on this subject between the SSA, DHS (Department of Homeland Security), and the Employer.

The individuals whose signatures appear below represent that they are authorized to enter into this MOU on behalf of the Employer and DHS respectively.

To be accepted as a participant in E-Verify, you should only sign the Employer's Section of the signature page. If you have any questions, contact E-Verify Operations at 888-464-4218.

Employer, Your Company Name

John Doe

Name (Please type or print)

Title

Electronically Signed

01/01/2009

Signature

Date

Verification

Department of Homeland Security - Division

USCIS Verification Division

Name (Please type or print)

Title

Electronically Signed

01/01/2009

Signature

Sample
E-Verify
Memo of Understanding - MOU
Electronic Signature Page

**CITY OF SPRINGFIELD
 BID FORM – PROPOSAL
 IFB #115-2010**

SUBMITTED BY _____
 Company Name

Pursuant to and in accordance with the above stated Invitation for Bid, the undersigned hereby declares that they have examined the IFB documents and specifications for the item(s) listed below.
 The undersigned proposes and agrees, if their Bid is accepted to furnish the item(s) submitted below, including delivery to Springfield, Missouri in accordance with the delivery schedule indicated below and according to the prices products/services information submitted.

ITEM	QTY	DESCRIPTION	UNIT PRICE	EXTENDED AMOUNT
1.	1 LS	<p>Removal, purchase and replacement of six (6) overhead doors in accordance with attached specifications: Price to include sections 1 -5 of the specification</p> <p>Mfg. _____ Model No. _____</p> <p>Complete Installation: _____ days after receipt of order.</p> <p>SHALL WARRANTY THE ABOVE EQUIPMENT FOR PARTS, LABOR AND TRAVEL FOR _____</p>	<p>\$ _____ Per LS</p>	<p>\$ _____</p>
2.	1 LS	<p>Optional door/hardware upgrade for removal, purchase and installation of six (6) overhead doors in accordance with attached specifications Price to include sections 1 – 6 of the specification</p> <p>Mfg. _____ Model No. _____</p> <p>Complete Installation: _____ days after receipt of order.</p> <p>SHALL WARRANTY THE ABOVE EQUIPMENT FOR PARTS, LABOR AND TRAVEL FOR _____</p>	<p>\$ _____ Per LS</p>	<p>\$ _____</p>

DELIVERY: F.O.B. DESTINATION

Prompt Payment Discount _____ % _____ Days, Net _____ Days

**CITY OF SPRINGFIELD
STATEMENT OF "NO BID"
IFB #115-2010**

**RETURN THIS PAGE ONLY IF YOUR COMPANY PROVIDES THE PRODUCTS/SERVICES BEING BID AND DECLINES
TO DO SO.**

WE, THE UNDERSIGNED, HAVE DECLINED TO BID ON YOUR **IFB #115-2010** FOR **OVERHEAD DOOR
REPLACEMENT** FOR THE FOLLOWING REASON(S):

_____ SPECIFICATIONS ARE TOO "TIGHT," I.E. GEARED TOWARD ONE BRAND OR MANUFACTURER ONLY
(PLEASE EXPLAIN BELOW).

_____ INSUFFICIENT TIME TO RESPOND TO INVITATION FOR BID.

_____ OUR PRODUCT SCHEDULE WOULD NOT PERMIT US TO PERFORM.

_____ UNABLE TO MEET SPECIFICATIONS.

_____ UNABLE TO MEET INSURANCE REQUIREMENTS.

_____ SPECIFICATIONS UNCLEAR (PLEASE EXPLAIN BELOW).

_____ OTHER (PLEASE SPECIFY BELOW).

REMARKS: _____

COMPANY NAME: _____

ADDRESS: _____

SIGNATURE AND TITLE: _____

TELEPHONE NUMBER: _____

DATE: _____